

УДК 629.3.02

## Конструирование автомобильных танкеров с учетом осевой нагрузки и боковой устойчивости

**А. Пападоджаннис, Т. Хондрос**

*В статье представлен разработанный метод системного проектирования, применяемый при конструировании автомобильных танкеров для перевозки опасных грузов. При расчете были учтены профиль и материал резервуара, крепление резервуара, нагрузка на оси, боковая устойчивость, а также правила и стандарты, затрагивающие успешное развитие транспорта и безопасность дорожного движения. Предложенный алгоритм применялся к 4-осевому автомобильному танкеру с одним резервуаром.*

## Road Tanker Design for Axle Load-Share and Lateral Stability

**A. Papadogiannis, T. Chondros**

*A systematic design approach applied to road tankers for transportation of dangerous goods is developed. Tank cross-section and material, axles' load-share, tank attachment, lateral stability, and applicability of Regulations and standards, affecting successful vehicle development and road safety are incorporated. The algorithm presented applies to 4 axles single unit road-tankers.*

**Introduction.** Design of road tankers for transporting hazardous goods is subject to specific regulations and norms, and standard procedures related to truck configuration, tank cross-section type, wheelbase, number of axles, and suspension type. Axles load share, roll stability, and vehicle handling characteristics vary drastically depending on road tanker configuration and the liquid load carried. Heavy road vehicles are complicated systems with a variety of possible failure modes, with significant impact on safety, the infrastructure and the environment [1–4].

Road tankers have a permanent multi-compartment tank fitted to chassis for the transportation of a range of products, liquids, gases or powders. Body, the tank for a road tanker, forms a critical element in the overall design specification, ensuring that vehicle is fit for purpose and performs tasks cost-effectively. Limited vehicle types are offered with standard vehicle manufacturers' pre-built bodies. For the majority of vehicle types not offered with pre-built bodies, buyers specify body, and usually detailed design. Body manufacturers help with tank design specifications and body material, and appropriate chassis configuration. Multi-axle vehicles are used to maximize weight distribution [5–6].

The relatively low roll stability of commercial trucks promotes rollover and contributes to the number of truck accidents [3–7]. Roll plane models



**ПАПАДОДЖАННИС  
АРГУС**  
(Университет Патры)

**Argyris S. Papadogiannis**  
(Patras, Greece, University of Patras)



**ХОНДРОС  
ТОМАС**  
(Университет Патры)

**Thomas G. Chondros**  
(Patras, Greece, University of Patras)

proposed by Rakheja et al [8–9] apply for the study of heavy vehicles dynamic rollover properties. Strategies controlling active rollover systems in single-unit heavy road vehicles, maximizing roll-stability, are investigated in [10]. Gross weight limits, axle weights, and payload limits for heavy vehicles are discussed in [11–16]. A method for payload optimization adopted by a fleet of road tankers is described in [17].

Road tankers design requires proper tank cross-section selection and correct location of the tank on vehicle chassis at an early design stage. Circular, elliptical, oval or similarly shaped tanks cross-sections are regarded as having good structural integrity for liquid cargo transportation. The best body size will normally be the smallest one necessary for the design task, allowing for minor changes in volume and equipment [18].

Truck chassis manufacturers provide the suggested location of the centre of gravity of the body and payload in the technical documentation specific to each vehicle model (chassis-cab drawing). On the other hand, tank manufacturers have to specify tank's cross-section shape and dimensions to fit a given chassis configuration. Tank shapes variations distinguish individual tank manufacturers one from another, also influencing road-tankers gross weight, overall length, wheel-base and axles load share. In this paper a systematic design algorithm for road tankers design is developed. Although critical design steps are addressed by the algorithm proposed, engineering judgement is required for a successful road tanker configuration [19].

The ADR Regulation [20] for road transportation of dangerous goods and the European norm

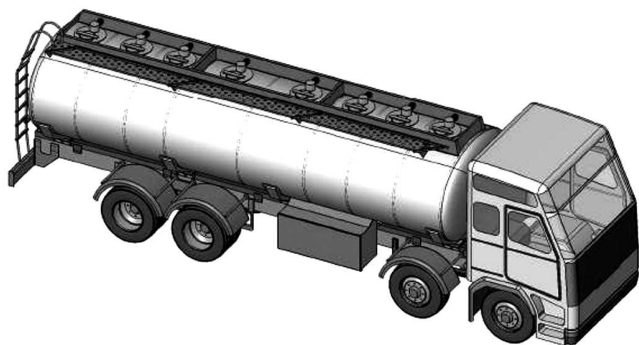

Figure 1: Four-axle, 33T gross weight road tanker

EN 13094/1994 [21] provide the guidelines for the design, construction and testing procedures of road tankers. Road tankers design prerequisites and legal constraints are very important issues also concerned with road safety and product development. Design of a road-tanker requires confirmation of vehicle's behavior in service, type approval requirements, and application of related regulations, and standards [22–23]. Safety is of paramount importance for road tankers transporting dangerous goods. Safety design features include structural integrity for the liquid cargo carried the ability of a tanker to resist fracture, rupture or puncture in case of roll-over or accident, conformity with specific regulations in force. A four-axle 33T road-tanker with eight compartments and tank roof protection is shown in Figure 1. Design issues must be balanced against efficiency, load carrying ability and cost [1].

Monitoring road tanker load-carrying capacity during the design stage ensures that maximum payload does not cause either gross weight or axle overloads. Axle overloads are affecting seriously vehicle's driving behaviour as gross weight overloads do. Provisions must be made for steering axle minimum loading in case of a partially loaded, or unloaded vehicle. Bogie axle maximum weights are complex and relate to the spacing of the number of close axles, providing maximum weight over the spread of the close axles. A comprehensive design algorithm for road-tankers axle load-share is presented in [24]. Lateral stability associated with transportation of liquid cargos, imposes specific requirements for road tankers design [25–28]. A method for identifying road-tankers' roll stability is described in [4].

A sequential procedure for a four axle 33T road-tanker design (Figure 1) and design evaluation is proposed herein. The proposed algorithm determines tank's CG position, tank filling capacity, axles load share and roll-over threshold. Vehicles' design parameters, and design constraints, are organized to provide a systematic solution for product design in conformity with the Regulations in force for the transportation of dangerous goods.

The method is suitable for application in two ways: First, by road tankers manufacturers for an initial determination of the vehicle's design parameters, i.e. selection of the proper tank for a given chassis selection, tank's cross-section de-

sign, proper positioning of the tank's CG on the chassis longitudinal axis to maximize axles load share and payload capacity, and enhance handling performance, road safety and power consumption. Second, as an evaluation tool for the estimation of the maximum permitted gross-weight and axles load share of the road tanker and its dynamic behaviour for roll-pitch and lateral stability in service.

**Road tankers type approval.** Vehicles carrying dangerous goods shall comply with specific design requirements for vehicles of categories N and O, [22–23]. Tank-vehicles with fixed tanks with a capacity of more than 3 m<sup>3</sup> intended for the carriage of dangerous goods in the liquid or molten state tested with a pressure of less than 4 bar, are tested to comply with the technical requirements of ECE Regulation No. 111 [25] for lateral stability. At the request of the manufacturer or his duly accredited representative, base vehicles of new motor vehicles and their trailers which are subject to approval may be type approved by a competent authority in accordance with ECE Regulation No. 105 [22] or Directive 98/91/EC [14].

European Standard EN 13094/2004 [21] specifies minimum requirements for the design and construction of metallic tanks with a maximum working pressure not exceeding 50 kPa gauge used for the transport of dangerous goods by road and rail, Tank Code «G» according to the ADR Regulation [20]. It also includes requirements for a system of identification of materials used in tank construction. This standard specifies requirements for openings, closures and structural equipment; and not service equipment, regulated by different norms and standards.

For vehicle type certification, the design process has to be approved by the competent authority, and specific design requirements for heavy vehicles transporting dangerous goods must be followed. For tank-body and equipment, loads must be correctly distributed longitudinally and transversely on chassis, and appropriate tank-chassis connection techniques [24]. Evaluation of axles loading is essential to fit the tank body on chassis, influencing vehicle handling, and safety. Additional requirements include: 25–30% gross weight distributed on front axle, maintaining steerability and braking performance; cabin to superstructure distance according

Table 1

VEHICLE TYPE	N3, 4 AXLES, 33T
WHEELBASE, mm	4 550–5 100
CHASSIS WEIGHT, kg	8 400–9 200
TANK LENGTH, mm	7 400–7 840
TANK WIDTH, mm	2 400–2 500
TANK HEIGHT, mm	1 650–1 840
TANK VOLUME, m <sup>3</sup>	26–30
TANK WEIGHT (AL), kg	2 500–2 900
WHEELBASE, mm	4 550–5 100

to Regulations specifications; limitations in length; positioning of under-ride guard; rear overhang; axle load-share; tank filling capacity, road tanker roll-over threshold; overloading calculation with 100% tank filling, must be stipulated by the relevant laws and regulations.

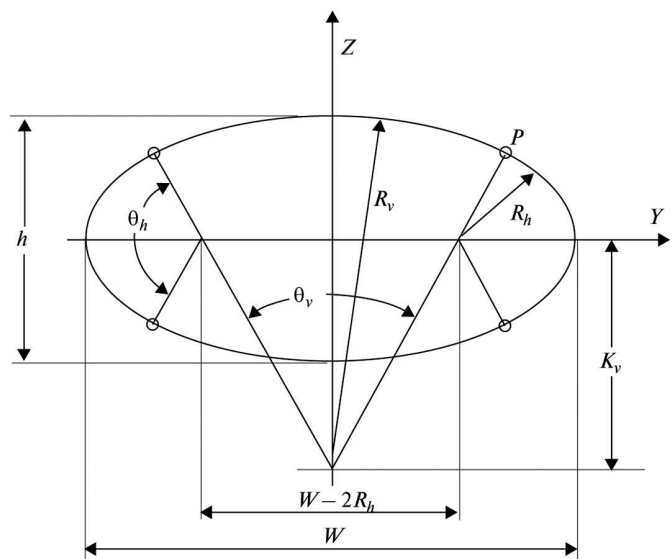

Figure 2: Tank cross-section coordinates

**Tank design.** Initial selection of tank cross-section is crucial for tanker design. Cross-sections shape and dimensions determine area and tank's overall length, thus affecting vehicle length and wall to wall turning radius. Short vehicle overall length facilitates vehicle's steering manoeuvres inside gas stations. Initial selection of an elliptic cross-section, with 2 450 mm limit for the long horizontal principle axis provides a good start for tank design.

Chassis length and cabin configuration yield constraints related to maximum tank length,

height, and furthermore, tank cross-section area providing maximum volume for the substances to be transported. A review of main design characteristics of existing N3, 4-axes, 33T gross weight, road tankers configurations is shown in Table I [4–5].

Tank cross-section design distinguishes tank manufacturers. The shape of tank cross-section followed by most tank manufacturers is elliptic, although circular shapes are gaining interest. Geometry of an elliptic cross-section with  $YZ$  coordinate system is shown in Fig. 2.  $R_v$ ,  $R_h$  and  $W$ , principal design variables provide different cross-section configurations to be evaluated [25–26].

Coordinates of change of curvature, point  $P$ , are given as

$$Y_P = \frac{W - 2R_h}{2\left(1 - \frac{R_h}{R_v}\right)}; Z_P = \sqrt{R_h^2 - \left(Y_P - \frac{W}{2} + R_h\right)^2} \quad (1)$$

and distance  $K_v$ , of arc with radius  $R_v$  from axis  $Y$  is

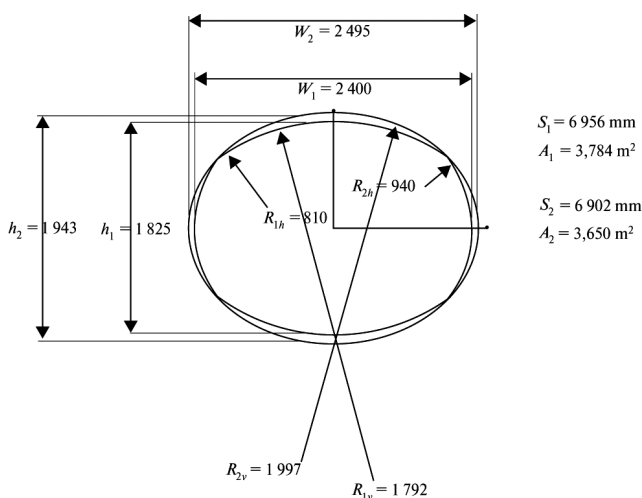

Figure 3. Selected solutions for two elliptic cross-sections

$$K_v = \frac{Z_P(W - 2R_h)}{2Y_P - W + 2R_h} \quad (2)$$

Angles  $\theta_v$  and  $\theta_h$  are given as

$$\theta_v = 2 \sin^{-1}\left(\frac{Y_P}{R_v}\right); \theta_h = 2 \sin^{-1}\left(\frac{Z_P}{R_h}\right) \quad (3)$$

Then, cross-section area is calculated as

$$A = \theta_h(R_h - t)^2 + \theta_v(R_v - t)^2 - (W - 2R_h)K_v \quad (4)$$

where  $t$  – shell thickness.

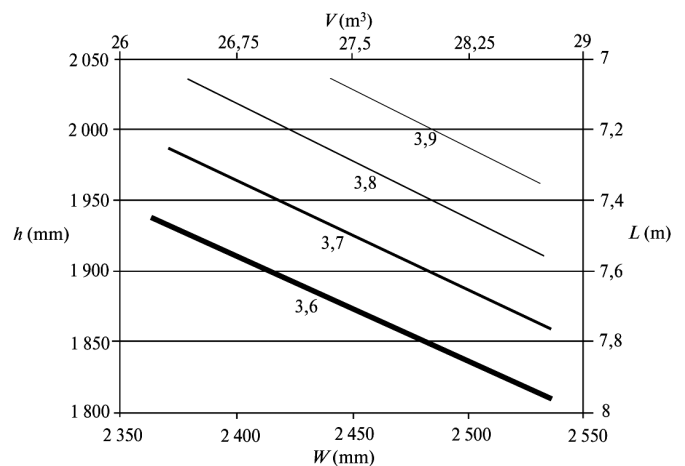

Figure 4. Tank area, tank length and volume, for various tank configurations

An algorithm in MATLAB [27] provides a set of cross-sections configurations for specific constraints based on the road-tanker to build. Dimensional constraints for the tank under design: cross-section maximum width and height 2 550 mm and 2 000 mm respectively, tank lengths range 7 000–8 000 mm. Figure 3 shows two elliptic cross-sections, 2 495 mm / 1 825 mm and 2 400 mm / 1 943 mm, principal axes dimensions, respectively. Tank dimensions and volume, and substances carried, determine tank weight and CG location on tank.

Tank weight depends on the number of compartments and equipment used. A parametric study relating tank cross-section, tank length and tank weight, provides a set of design solutions for tanks as shown in Figure 4 [1, 28–29].

At this stage of the design process, chassis and tank configurations have to be linked, in a way to fulfil appropriate norms and standards for road tankers transporting dangerous goods, and furthermore, provide good design characteristics of the road tanker to be built [1, 28–29]. In this view, tank location on chassis, axle load share, and lateral stability have to be evaluated, prior to final detailed design of the tank and its attachments with chassis. From Figure 3 appropriate tank providing good design characteristics of the road tanker configuration.

Tank configurations, similar to the two ones depicted in Figure 4, associated with filling capacity, and the substances carried, result in a variety of tank lengths, gross-weight and C.G. height, and consequently, chassis axles load sharing and lateral stability threshold. Available tank configurations

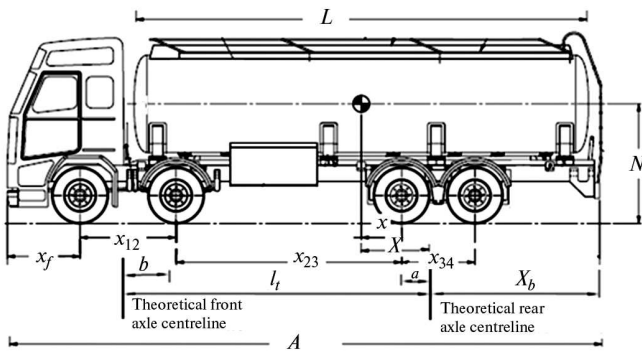

Figure 5: Theoretical wheelbase, main dimensions for a 33 T 4-axle road tanker

from the preceding analysis will be used as a verification tool for gross weight; axles load share, and lateral stability of the road tanker.

**33T Road tanker model axles load-share.** Selection of the most appropriate tank superstructure to fit a specific chassis configuration yields a multitude of possible solutions. The parameters of this design process are infinitely varied, and therefore difficult to summarize in a simple design formula [1, 28–31]. Location of the tank on chassis requires the solution of a set of equilibrium equations regarding axles load share. Effective axles load share requires the determination of vehicle mass with cabin, before fitting the body and equipment [17–19, 24, 32–34].

Prior to any calculation performed, the vehicle chassis must be weighed: without the driver, full fuel tank, handbrake released, and vehicle secured with chocks. If fitted with air suspension, the vehicle must be raised to normal driving position, liftable axles are lowered, and any moving-off aid is not actuated. Weighing is performed under the following sequence: front axle(s), rear axle(s) and the whole vehicle as a whole. Two portable scales may be used to weigh each axle separately [24].

Dimensions and theoretical wheelbase  $l_t$  for a four-axle road tanker are shown in Figure 5, tank CG located at distance  $x$  from drive third axle, chassis CG located on top of frame between front steering axles is determined after chassis final selection.

Theoretical wheelbase  $l_t$  for the four-axle road tanker shown in Figure 5 is calculated as [4, 24, 32–33]:

$$l_t = x_{23} + \frac{W_1 x_{12}}{W_1 + W_2} + \frac{W_3 x_{34}}{W_3 + W_4}, \quad (5)$$

where  $x_{12}$ ,  $x_{23}$  and  $x_{34}$  is the distance between front axles 1 and 2, axles 2 and 3, and rear axles 3 and 4 respectively,  $W_i$  loading capacity for axle  $i$ .

Location  $a$  and  $b$  of theoretical front and rear bogies centerlines from axles 2 and 3 are calculated as:

$$\alpha = \frac{W_4 x_{34}}{W_3 + W_4}; \quad (6)$$

$$b = \frac{W_1 x_{12}}{W_1 + W_2}. \quad (7)$$

Location of tank on chassis is defined by distance  $x$ , tank's C.G. from drive axle. This distance  $x$ , is the design variable that defines optimal tank CG location on chassis. An algorithm developed provides solutions concerning CG location on chassis longitudinal axis that have to be related with road tanker lateral stability parameters. Truck wheelbase is fixed, or a variable, in this analysis. It is a variable for design of a new tank truck, or fitting of an existing tank to a new truck. It is fixed when a new tank is being fitted to an existing vehicle. Distance  $X$ , the tank's CG from rear bogie centerline is calculated as:

$$X = x + \alpha. \quad (8)$$

A tank may be designed to haul products with a range of density. A carrier that does this will often operate with a partially filled tank at maximum gross weight, or overloaded if the tank is filled more than this. Normally, multiple compartment tanks provide flexibility for transporting variable density products, by loading full compartments only, and avoid sloshing of liquid cargo. Load share  $\Omega_F$  and  $\Omega_R$  for front and rear bogies respectively, is calculated as:

$$\Omega_F = \frac{\Omega \alpha_f (x + a)}{(a + b + x_{23})}; \quad \Omega_R = \frac{\Omega \alpha_f (b + x_{23} - x)}{(a + b + x_{23})}, \quad (9)$$

where  $\Omega$  is max rated payload and tank weight, and  $\alpha_f$ , the tank fill factor. Load sharing  $\Omega_{f1}$  and  $\Omega_{f2}$  for front axles 1 and 2, and  $\Omega_{r1}$ ,  $\Omega_{r2}$  for rear axles 3 and 4 respectively, is calculated as:

$$\Omega_{f1} = \frac{W_2 x_{12}}{W_1 + W_2} \Omega_F; \Omega_{f2} = \frac{W_1 x_{12}}{W_1 + W_2} \Omega_F; \quad (10)$$

$$\Omega_{r1} = \frac{W_4 x_{34}}{W_3 + W_4} \Omega_R; \Omega_{r2} = \frac{W_3 x_{34}}{W_3 + W_4} \Omega_R.$$

Payload and body weight share  $G_F$  and  $G_R$ , on front and rear bogies centreline must lay below corresponding capacities  $W_F$  and  $W_R$

$$G_F \leq W_F; \quad G_R \leq W_R, \quad (11)$$

where  $W_F$  and  $W_R$  front and rear bogie rated capacity, respectively.

Equations (15) yield

$$W_F \geq \Omega_F + AR_{FRONT}; \quad W_R \geq \Omega_R + AR_{REAR}, \quad (12)$$

where  $AR_{FRONT}$  and  $AR_{REAR}$  chassis and cab curb weight axles load share.

Solution of Equations (5–12) for different tank configurations, varying tank filling factor  $\alpha_f$  and tank CG position  $x$ , is shown in Figure 6. Tank design parameters in relation with vehicle chassis characteristics yield a set of axles load share values, under the following assumptions: reaction road forces are applied at the center of the tires, vehicle structure is assumed to be rigid, vehicle is symmetric about its centerline, and lateral deflection of the

suspension is negligible. Figure 6, left, shows ratio of front and rear bogies load-share versus rated capacity respectively, for varying tank filling factor and tank CG position. Front axle load share versus gross weight corresponds to lines with upwards inclination to the right.

Figure 6, right, shows front and rear axle load-share versus road tanker gross weight ratio, for varying tank filling factor and tank CG position. Front axle load share corresponds to lines with upwards inclination to the right. Points of intersection of lines with high load share factors (in the range of 90–95%) correspond to preferable tank CG distance from drive axle. Other design restrictions (i.e. cabin-tank clearance, rear overhang limit) may lead to different tank CG distance from drive axle, this resulting in lower axles load-share. As a design rule, points of intersection of similar axles load-share factors have to be selected. This guarantees that similar overloading factors of front and rear axles are expected, in case of road-tanker overloading. From Figure 6 tank’s CG location on chassis longitudinal axis is now feasible. Any other design restrictions and regulations limitations concerning tank location on chassis must be considered at this stage.

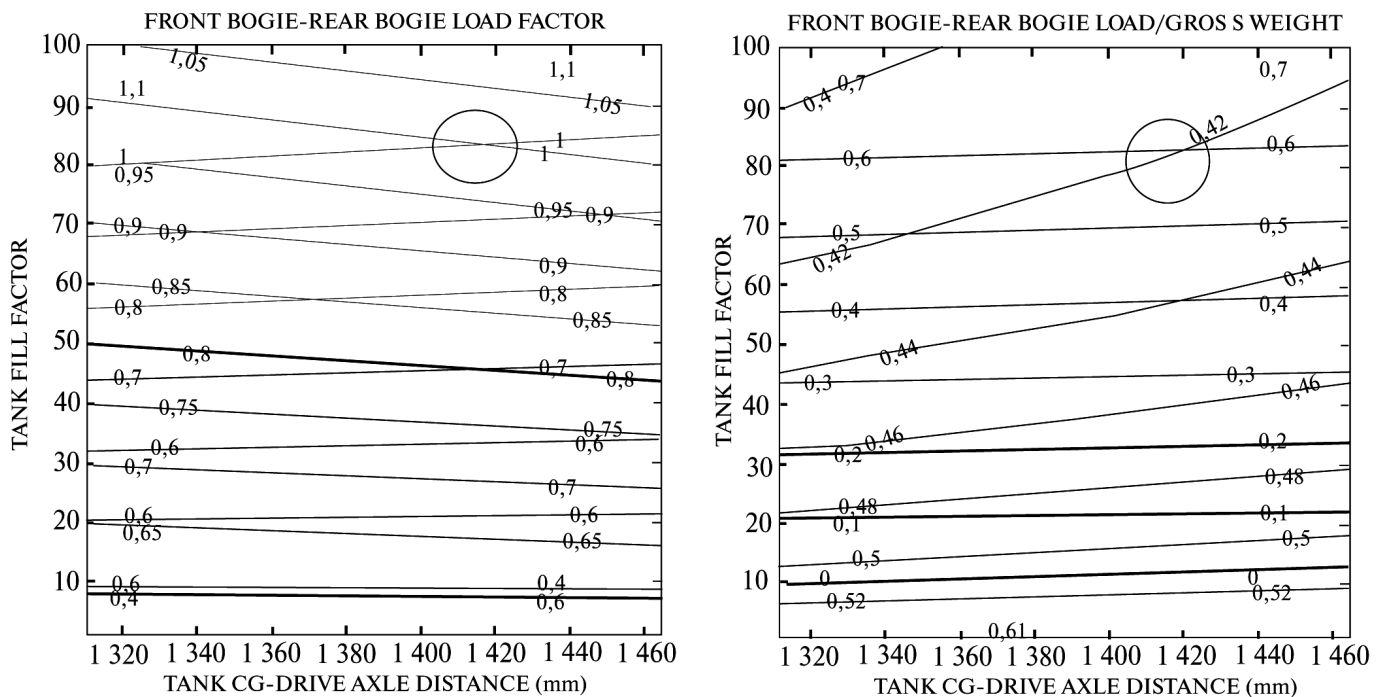

Figure 6: Four-axle 33 T road tanker, 24 m<sup>3</sup> tank. Left: Front bogie — rear bogie load factor versus tank CG-drive axle distance and filling factor. Right: Front bogie — rear bogie load/gross weight

Furthermore, the algorithm stores data similar to those depicted in Figure 6 for road-tanker's performance and various filling factors. This is quite helpful for logistics and safety engineers for planning loading and unloading of multi-compartments road tankers. The large number of tank compartments, enhances transportation safety, since fully loaded compartments prevent liquid cargo sloshing.

**4-Axle road tanker lateral stability.** Tank position, apart from axles load share, affects roll stability of the road-tanker, both on vehicle dynamic response and lateral stability and associated factors resulting in lateral shift of the centre of gravity (axle roll stiffness, suspension roll stiffness, height of the centre of gravity, track width, size and weight variables) [1, 35–38]. A combined mathematical model-experimental method was incorporated to assess compliance of the road tanker under design with ECE-111 Regulation [4, 39]. Dynamic roll-over indicators in terms of Critical Distance Ratio (CDR) are used for the calculation of static rollover threshold, the steady lateral acceleration which causes rollover of the vehicle. Figure 6 shows a simple static roll plane model with two degrees of freedom: sprung mass and unsprung mass roll angles ( $\theta_u$  and  $\theta_s$ ),  $m_s$  sprung mass,  $m_u$  unsprung mass,  $H_{CGs}$  sprung mass CG height,  $H_{CGu}$  unsprung mass CG height,  $m$  roll center height,  $C_{DRi}$  axle  $i$  roll stiffness due to tires vertical stiffness,  $C_{DGi}$  roll stiffness of axle  $i$  due to suspension vertical stiffness.

Total roll stiffness ( $C_{DREST}$ ) resisting on roll motion is contributed by vertical stiffness of suspension springs ( $F_{GVi}$ ) and suspension components stiffness, other than springs, i.e. trailing arm systems in air suspensions, anti-roll bars in steel steering axle suspensions, tires vertical stiffness ( $F_{Rvi}$ ) [36–39].

Taking moments about each roll centre in Figure 6, and assuming small rotation angles, two equations of motion can be derived:

$$m_s q_c H_{CGs} + m_u q_c H_{CGu} + m_s g (H_{CGs} - m) \theta_{tot} = (C_{DRi} - m_s g m - m_u g H_{CGu}) \theta_u; \quad (13)$$

$$m_s (H_{CGs} - m) q_c + (m_s g (H_{CGs} - m) + C_{DGi}) \theta_{tot} = -C_{DGi} \theta_u; \quad (14)$$

where  $\theta_{tot}$  and  $\theta_u$  roll angles of sprung and unsprung masses respectively. Equations (13) and (14) yield rollover threshold as:

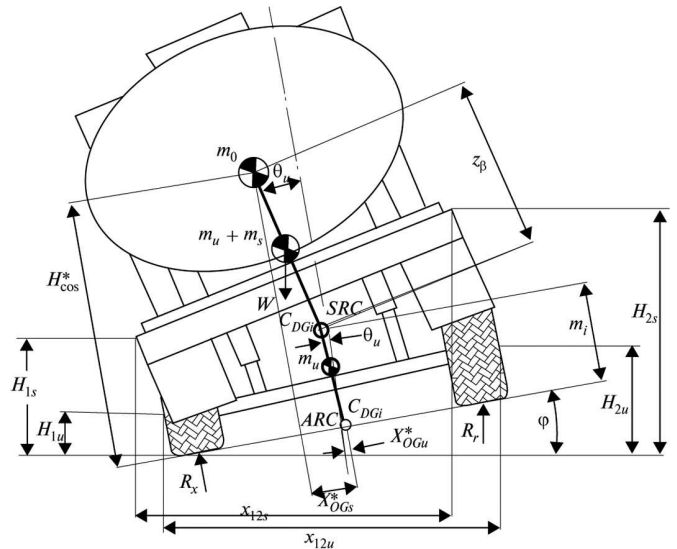

Figure 7: Road-tanker at tilted position for ECE-111 Regulation compliance study

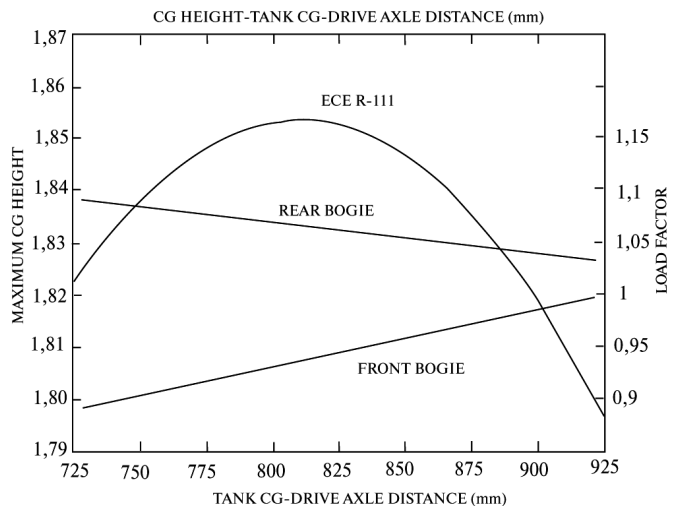

Figure 8: Four-axle 33 T road tanker 28.4 m³ tank. Maximum tank CG height versus tank CG — drive axle distance. Left: Front bogie — rear bogie load factor versus tank CG-drive axle distance and filling factor. Right: Front bogie — rear bogie load factor versus gross weight

$$q_c / g = [m_s g (H_{CGs} - m) \times (C_{DRi} - m_s g m - m_u g H_{CGu}) + C_{DGi} (m_s g H_{CGs} + m_s g H_{CGu} - C_{DRi})] \theta_u / [m_s g (H_{CGs} - m) (m_s g m + m_u g H_{CGu}) - C_{DGi} (m_s g H_{CGs} + m_s g H_{CGu})] \quad (15)$$

Rollover threshold is defined as the lateral acceleration when one wheel lifts off ground. At this condition, unsprung mass roll angle is:

$$\theta_u = (m_s + m_u)g/F_{RVI}T, \quad (16)$$

where  $T$  track width,  $F_{RVI}$  tire stiffness. Substituting (16) into (15) yields road-tanker’s rollover threshold [39].

This simplified model is not dynamically similar to road tanker under design, because: (i) it only has one axle, and therefore does not account for the effects of multiple axles, including roll/torsion and bounce/pitch coupling; (ii) its inertia is all concentrated above the suspension. Nevertheless, this model is representative of the parameters affecting rollover stability of the road-tanker under design, providing a very good estimate of lateral stability characteristics at this design stage.

An algorithm developed in MATLAB environment [27] was used for a parametric solution of Equations (13–16) for road tanker axles share, ver-

sus varying tank CG location and tank configurations developed previously, and results are shown in Figure 8. The curve in Figure 8 represents tank CG heights for which critical roll-over angle, 23 degrees as defined by Regulation R-111, occur for the road-tanker. Then tank CG height has to be selected in the area below the curve, yielding the associated tank CG-drive-axle distance. In the same Figure 8, two lines represent solutions of the system of Equations (5–12) corresponding to axles load-share depending on tank CG distance from drive axle. Front – rear bogies loading is denoted by load factor, the ratio of bogie loading versus rated bogie loading.

**Tank design.** From the preceding analysis, an eight compartments Al-5186 H111 tank detailed design and stress analysis is performed with a commercially

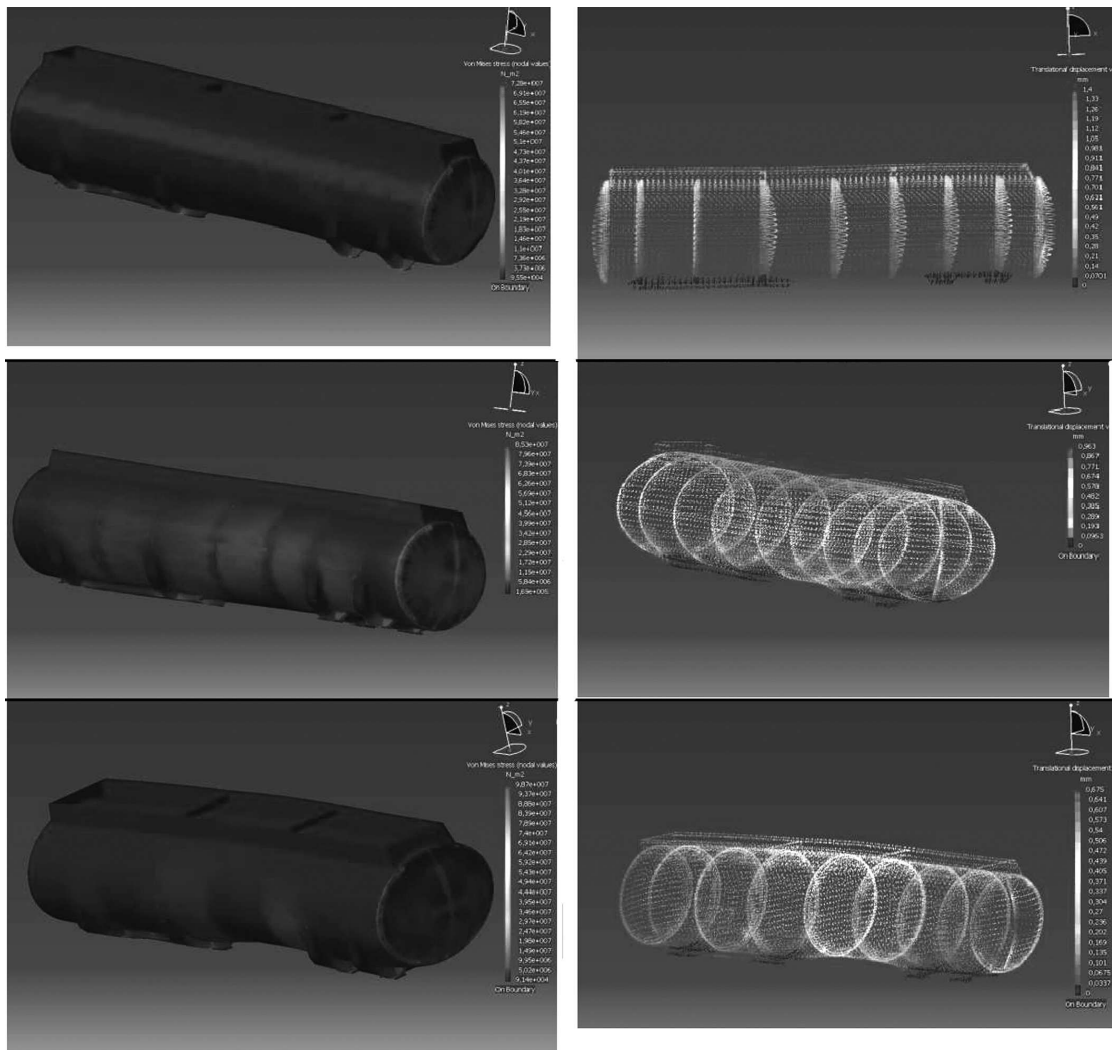

Figure 9: Stress concentration for 2g braking, 1g lateral acceleration, 2g vertical upwards acceleration, and – 1g vertical downwards acceleration



available finite elements algorithm (Figure 9). Material properties: Young's modulus  $E = 69,50$  GPa, Poisson ratio  $\nu = 0,33$ , tensile strength  $S_u = 275$  MPa, yield strength  $S_y = 125$  MPa, elongation (20%)  $A = 24$ , material density  $\rho = 2\,720$  kg/m<sup>3</sup>, welding factor  $\lambda = 0,80$ . Loading cases corresponding to those proposed by the ADR Regulation and EN 13094/2004 were incorporated to the analysis. Tank is filled with liquid cargo 845 kg/m<sup>3</sup> density, internal vapor pressure 0,150 bar, static pressure test 0,400 bar, external pressure  $-0,030$  bar, loadings corresponding to: braking 2g, lateral acceleration 1g, vertical upwards acceleration 2g, vertical downward acceleration  $-1g$ .

Stress concentration results for various loading conditions are shown in Figure 9. Stresses corre-

spond to braking (up), lateral (middle) and vapor pressure (down). Loadings were compared with calculations suggested by EN 13094/2004 [21] performed with the aid of a spreadsheet, and were well below rated stresses and safety factor recommended.

Tank loading description and Finite Elements Analysis provide data for a detailed tank design, calculation of supports and attachments with chassis, tank weight, manholes and equipment location on tank. From this stage of the design process onwards, detailed configuration of the road tanker follows [1, 28–31].

**Synthesis.** A four axle 33T gross weight, N<sub>3</sub> road tanker according to UN standardization [13–14, 20–23], chassis weight with cabin 9 200 kg, 10 000 mm

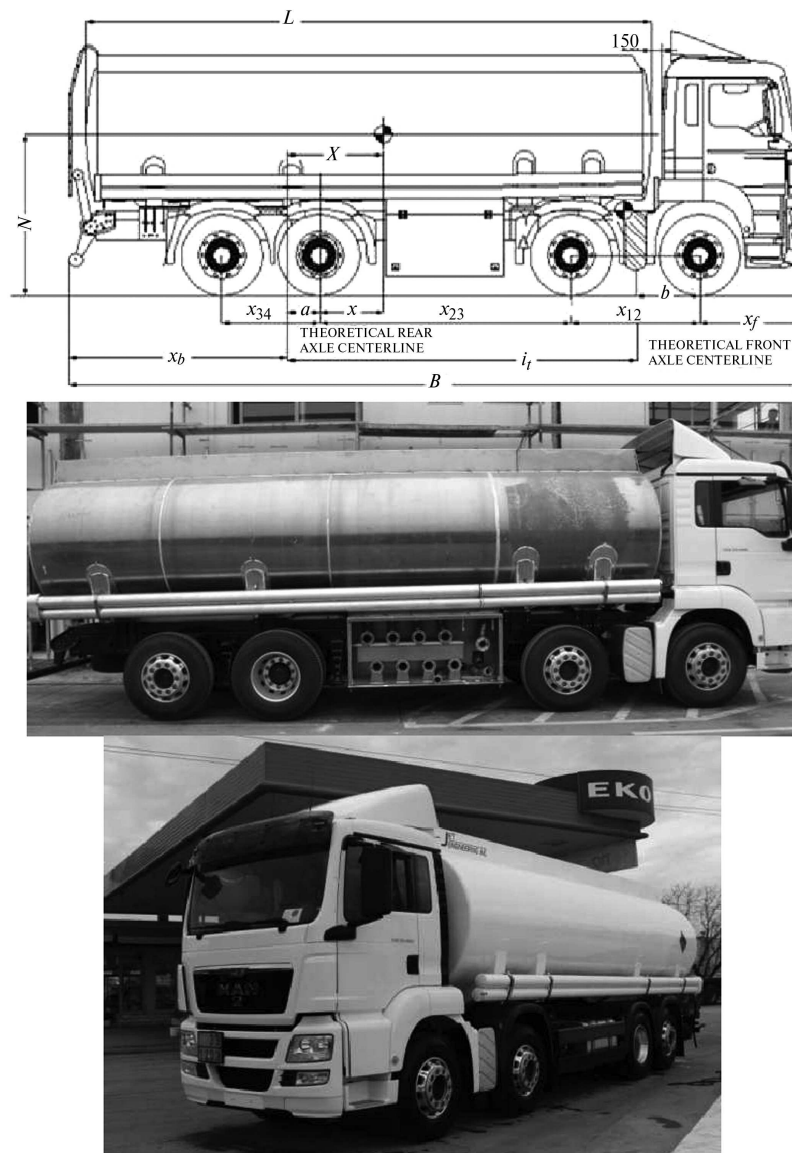

Figure 10: 33T 4-axle road tanker, design, test vehicle, finished vehicle

maximum length, 2 500 mm wide, will be investigated here. Design constraints for the road tanker are given as: maximum vehicle length 10 m, cross-section maximum width and height 2 550 mm and 2 000 mm respectively.

From Figure 3, tank cross-sections configurations are evaluated and related to tank lengths in the range 7 000 mm — 8 000 mm, providing tank volumes (Figure 4). The algorithm calculates tank weight and cargo load, and compares chassis and cabin kerb weight, to keep road tanker gross-weight below 33T. This procedure yields a range of cross sections, tank lengths and weights. For the vehicle chassis adopted above and Figures 3 and 4, cross-section with the following characteristics is selected: cross-section curvature radii  $R_1 = 1\,792$  mm,  $R_2 = 810$  mm, tank width  $W = 2\,495$  mm, tank height  $H = 1\,826$  mm, tank length  $L = 7\,610$  mm, volume  $V = 28,4$  m<sup>3</sup>, cross section perimeter  $S = 6\,912$  mm, cross section area  $A = 3\,652$  m<sup>2</sup>. Radii of curvature  $R_1$  and  $R_2$  conform to paragraph 6.2.1 of EN13094/2004 ( $R_1 < 3m$ ,  $R_2 < 2m$ ). From tank dimensions and material aluminium alloy 5 186 H-111, 8 compartments, and appropriate equipment and control devices, tank weight yields 2 700 kg.

From the diagrams in Figures 6, and 9, the tank CG-drive axle distance is selected in a way that load share versus rated capacity for both axles bogies is around 1.0, it conforms to the range permitted by truck manufacturer, the ADR [20—22] and ECE-111 [26—28, 35—38] requirements. For vehicles with a rear lift axle, it must be considered that, with this axle in the raised position, the effective wheelbase is reduced, whereas the rear overhang is increased. It is therefore required that the centre of gravity of body and payload is located in front of the centreline of the driving axle. Tank detailed design and location of tank CG on chassis leads to the detailed drawing of chassis and tank and road-tanker synthesis (Figure 10) [1, 28—34, 39—40].

## Conclusions

The proposed algorithm can be used as a design and evaluation tool from tank manufacturers either for optimum chassis selection for an existing tank type or design of a new tank to be fitted on existing vehicle chassis. The method ensures payload maximization, a sensible load distribution among axle

bogies, and furthermore, provides an estimation of the road tanker's handling and roll-over characteristics from an early design stage.

With the algorithm developed the superstructures' CG positioning is determined in both longitudinal and vertical plane, providing vehicle and superstructure design, as well as road-tanker's operational characteristics in a complete form. The method applies to vehicles with 4 axles and can be easily adapted for three-axle and two axle single-unit road-tankers.

## Acknowledgments

Acknowledgments are addressed to Jet Engineering S.A. (jetengsa@otenet.gr), a major road tankers manufacturer in Greece, and CEOs, Engineers A. Grammatikos and N. Damalas for their support to this project. This project was financed by the company in the frame of a research contract with the Scientific Committee of the University of Patras.

## References

1. Dimarogonas A.D., *Machine Design A CAD Approach*, John Wiley and Sons, Inc. N.Y. 2001.
2. Gerdes J.C. Principal Investigator:, Co-Investigators: P. Yih, K. Satyan, 2002. *Safety Performance and Robustness of Heavy Vehicle AVCS*. California PATH Program Year One Report for MOU 390, Department of Mechanical Engineering — Design Division Stanford University.
3. European Transport Safety Council, 2001. *Priorities for EU Motor Vehicle Safety Design*, www.etsc.be, Brussels.
4. Chondros T.G., Michalos G., Michaelides P., Fainekos E. 2007 An approximate method for the evaluation of the roll stiffness of road tankers *Proceedings of the I MECH E Part D Journal of Automobile Engineering*. **221**(12), pp. 1499—1512.
5. Lorry weights: a consultation document — maximum permitted weight Department of Transport Zone 2/11 Great Minster House, 76 Marsham Street, London SW1P 4DR.
6. Tesar M., 2005. The influence of liquid load motion on rollover stability of road tankers International. *Journal of Heavy Vehicle Systems*. **12**(2), pp. 121—138.
7. Ervin R.D., 1986. Dependence of truck roll stability on size and weight variables. *International Journal of Vehicle Design*. **7**(5—6), pp. 192—208.
8. Winkler C.B., Karamihias S.M. and Bogard S.E., 1992. Roll stability performance of heavy vehicle suspensions SAE Technical Paper Series International Truck and Bus Meeting and Exposition; Toledo, OH, USA. pp. 1—14.
9. Goldman R.W., El-Gindy M. and Kulakowski B.T., 2001. Rollover dynamics of road vehicles: Literature survey *Heavy Vehicle Systems*. **8**(2), pp. 103—141
10. Yang X., Rakheja S. and Stiharui I., 1998. Identification of Lateral Dynamics and Parameter Estimation of Heavy Vehicles. *Mechanical Systems and Signal Processing*. **12**(5), pp. 611—626.
11. Liu P.J., Rakheja S. and Ahmed A.K.W., 2001. Dynamic roll instability analysis of heavy vehicles using energy approach *International Journal of Heavy Vehicle Systems*. **8**(2), pp. 177—195.

12. Sampson D.J.M. and Cebon D., 2003. Achievable roll stability of heavy road vehicles, Proceedings of the Institution of Mechanical Engineers Part D: Journal of Automobile Engineering. 217 (6), pp. 791—806.
13. TRANS/WP.29/343/Rev.12 11 February 2004. Classification and Definition of Power-Driven Vehicles and Trailers.
14. Commission Directive 98/91/EC of 14 December 1998 adapting to technical progress Council Directive 70/156/EEC on the approximation of the laws of the Member States relating to the type-approval of motor vehicles and their trailers intended for the carriage of dangerous goods.
15. Cole D.J., 2001. Fundamental Issues in Suspension Design for Heavy Road Vehicles. *Vehicle System Dynamics*. 35(4—5), pp. 319—360.
16. Barnett C., 2005. Same-day suspension. *Commercial Motor* 201, 5018 (3), p. 52.
17. Lorry weights: a consultation document — maximum permitted weight Department of Transport Zone 2/11 Great Minster House, 76 Marsham Street, London SW1P 4DR.
18. Lee D., 1979. Optimal Loading of tankers *Journal of the Operational Research Society*. 30(4), pp. 323—329.
19. Rumold W., 2001. Modeling and Simulation of Vehicles Carrying Liquid Cargo. *Multibody System Dynamics*. 5, pp. 351—374.
20. ADR 2007 EU Directive 2006/89/EC The transportation of dangerous goods by road. ECE/TRANS/185, Vol. I and II European Agreement Concerning the International Carriage of Dangerous Goods by Road.
21. EN 13094/2004 March 2004. Tanks for the transport of dangerous goods — Metallic tanks with a working pressure not exceeding 0,5 bar — Design and construction provide the guidelines for the design and construction of road tankers.
22. European Standard EN 12972 April 2001, *Tanks for transporting of dangerous goods-Testing, inspection and marking of metallic tanks*, European Committee for Standardization.
23. Commission Directive 2001/116/EC of 20 December 2001 adapting to technical progress Council Directive 70/156/EEC on the approximation of the laws of the Member States relating to the type-approval of motor vehicles and their trailers.
24. Papadogiannis A.S., Farmakopoulos A.G. and Chondros T.G., 2009. *International Journal of Heavy Vehicle Systems*. 17(3/4), pp. 256—275. Road-tankers axles load share design.
25. Muškis A.D., 1975. *Advanced Mathematics for Engineers*. Mir Publishers, Moscow.
26. Bakhvalov N.S., 1977. *Numerical Methods*. Mir Publishers, Moscow.
27. MATLAB 7.1. Numeric Computation and Visualization Software.
28. Dimarogonas A.D., 1988. *Computer Aided Machine Design*. Englewood Cliffs, NJ:Prentice-Hall.
29. Orlov P., 1976. *Fundamentals of Machine Design*, (5-volumes English Translation). Mir Publishers, Moscow.
30. Erdman A. and Sandor G.N., 1984. *Mechanism Design, Analysis and Synthesis*. Prentice-Hall, Englewood Cliffs, N.J.
31. Norton R., 1994. *Design of Machinery*. McGraw-Hill N.Y.
32. Artamonov M.D., Ilarionov V.A. and Morin M.M., 1976. *Motor Vehicles, Fundamentals and Design*. Mir Publishers, Moscow.
33. Lukin P., Gaspariyants G. and Rodionov V., 1989. *Automobile Chassis Design and Calculations*. Mir Publishers, Moscow.
34. Wong J.Y., 2008. *Theory of Ground Vehicles* Wiley.
35. Regulation No. 111, E/ECE/324 Rev.2/Add.110 E/ECE/TRANS/505A rollover stability of tank vehicles of categories N<sub>2</sub>, N<sub>3</sub>, O<sub>3</sub> and O<sub>4</sub> intended for the carriage of dangerous goods.
36. Dimarogonas A.D., 1996. *Vibration for Engineers*. Upper Saddle River, NJ, Prentice-Hall; second edition.
37. Fu T.T. and Cebon D., 2002. Analysis of a truck suspension database International. *Journal of Vehicle Design, Heavy Vehicle Systems*. 9(4), pp. 281—297.
38. Dahlberg E. and Stensson A., 2006. The dynamic rollover threshold — a heavy truck sensitivity study. *International Journal of Vehicle Design*. 40 1/2/3/, pp. 228—250.
39. Artobolevski I.I., 1975. *Mechanisms in Modern Engineering Design, A Handbook for Engineers Designers and Inventors*. Five Volumes (English Translation). Mir Publishers, Moscow.
40. Chemilevski D., Lavrova E. and Romanov V., 1984. *Mechanics for Engineers*. Mir Publishers, Moscow.

## Information about the authors

**Argyris S. Papadogiannis**, Mechanical Engineer, Design engineer in automotive industry, Ph.D. candidate, Mechanical Engineering and Aeronautics Department, 265 00 Patras, Greece. (e-mail: papadogiannisgr@yahoo.gr).

**Thomas G. Chondros**, Mechanical Engineer (PhD), Associate Professor in Dynamics and Machine Theory, University of Patras, Mechanical Engineering and Aeronautics Department, 265 00 Patras, Greece. (e-mail: chondros@mech.upatras.gr, author receiving correspondence).